

• **Caratteristiche tecniche**  
 • **Specifications**  
 • **Caractéristiques techniques**  
 • **Technische Eigenschaften**

**Accessori**  
**Optionals**  
**Accessoires**  
**Zubehör**

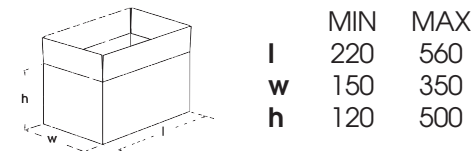

- Magazzino cartoni capacità 80÷150 scatole
- Box storing capacity 80÷150 boxes
- Magasin de cartons capacité 80÷150 cartons
- Fachschachtel Magazin Leistung 80÷150 Schachtel

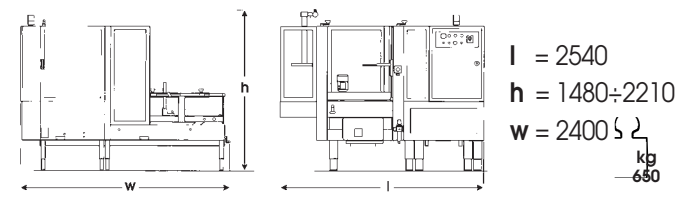
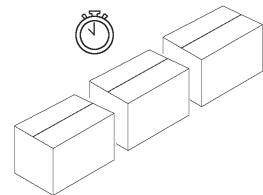

- Produzione media 7÷12 scatole/min.
- Output: 7÷12 boxes per minute
- Production moyenne: 7÷12 boîtes/min
- Leistung: 7÷12 Schachtel/Min.

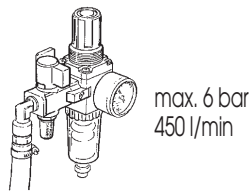

max. 6 bar  
450 l/min

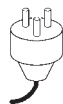

**380÷440** • Trifase • 3 Phase  
 • Tri-phasé • 3-phasing

**220÷240** • Monofase • Single phase  
 • Mono-phasé • 1 phasing

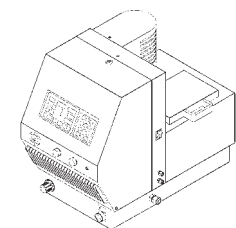

- Capacità serbatoio Hot Melt = kg. 5
- Hot-Melt tank capacity = kg. 5
- Capacité réservoir Hot-Melt = kg. 5
- Hot-Melt Tank Kapazität = kg. 5

- Capacità di fusione: 9 kg/ora
- Melting capacity: 9 kg/hour
- Capacité de fusion: 9 kg/heure
- Schmelzenkapazität: 9 kg/Stunde

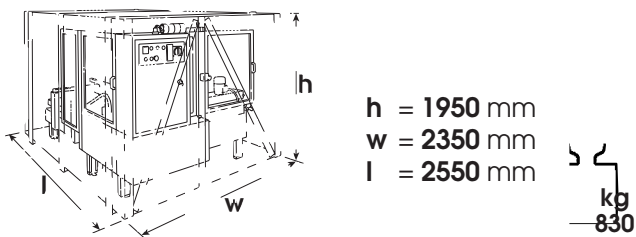

**AS77**

- Set ruote Ø100 mm • Casters • Roues • Satz Umlaufräder



**AS80**

- Set gambe più alte (600 mm) • Higher legs (600 mm/24") • Pieds plus hauts (600 mm) • Höhere Stützen

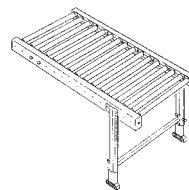

**RN/RG**

- Piani a rulli • Idler roller conveyors • Plans de rouleaux • Rollenbahnen

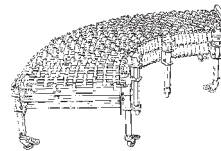

**GTM/GTL/GTR**

- Piani a rulli estensibili • Extensible conveyors • Plans de rouleaux extensibles • Ausziehbare Rollenbahnen

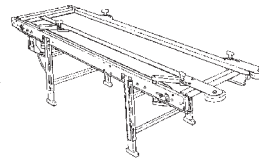

**CT 1/2/3/4**

- Trasportatori a tappeto • Powered belt conveyors • Transporteurs motorisés à tapis • Angetriebene Bandförderer

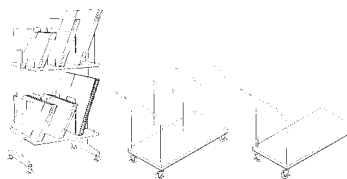

**M1/2/3/4**

- Magazzino cartoni • Carton-storage carts • Dépôt cartons • Kartonlager

**HM145-SX**

**HM145-DX**

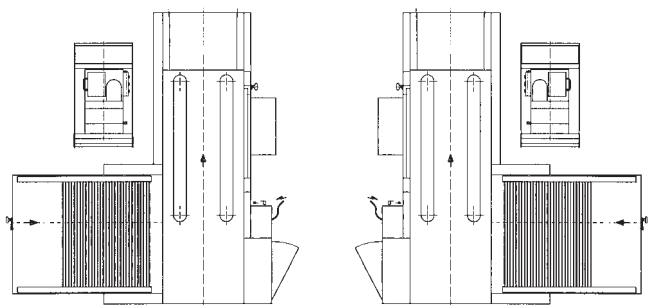

Linkx Systems Ltd, Anson House, Ellough, Beccles, NR34 7TJ  
 Tel:- +44(0)1502 713 777  
 www.siat.co.uk / www.linkx.co.uk

**SIAT**  
 by Linkx Systems

# SIAT

by Linkx Systems

*the new generation*



## HM145 Hot Melt

Formatore automatico

Automatic Case Erector

Formeuse automatique de caisse carton

Automatischer Fachschachtelaufrichter

# HM145 - Formatore automatico - Automatic Case Erector - Formeuse auto

Il formatore automatico HM145 preleva, forma e incolla le falde inferiori di scatole in cartone con adesivo Hot Melt inviandole chiuse alla successiva fase di riempimento. Adatto per produzioni fino a 700 scatole/ora, in funzione del formato. Le operazioni per il cambio formato sono semplici e veloci. Rispondente alle norme CE di sicurezza, è stato studiato per un facile impiego anche da parte di personale non specializzato.

The automatic Case Former HM145 draws, erects and glues with Hot Melt the bottom flaps of carton boxes, ready then to be filled. It can prepare up to 700 boxes/hour, according to the size. The machine adjustments to the carton dimensions are easy and fast. It conforms the CE regulations and does not require skilled operators.

- Manovelle regolazione contrasto altezza cartoni
- Box height regulation handles
- Manivelles réglage différente hauteur cartons
- Regelungskurbel Kontrast Kartonshöhe

- Stop Emergenza
- Emergency Stop Button
- Stop d'urgence
- Not-Ausschalter

- Indicatore luminoso
- Alarm light
- Lampe témoin
- Lichtzeiger

- Pannello di controllo
- Control Panel
- Panneau des commandes
- Kontrolltafel

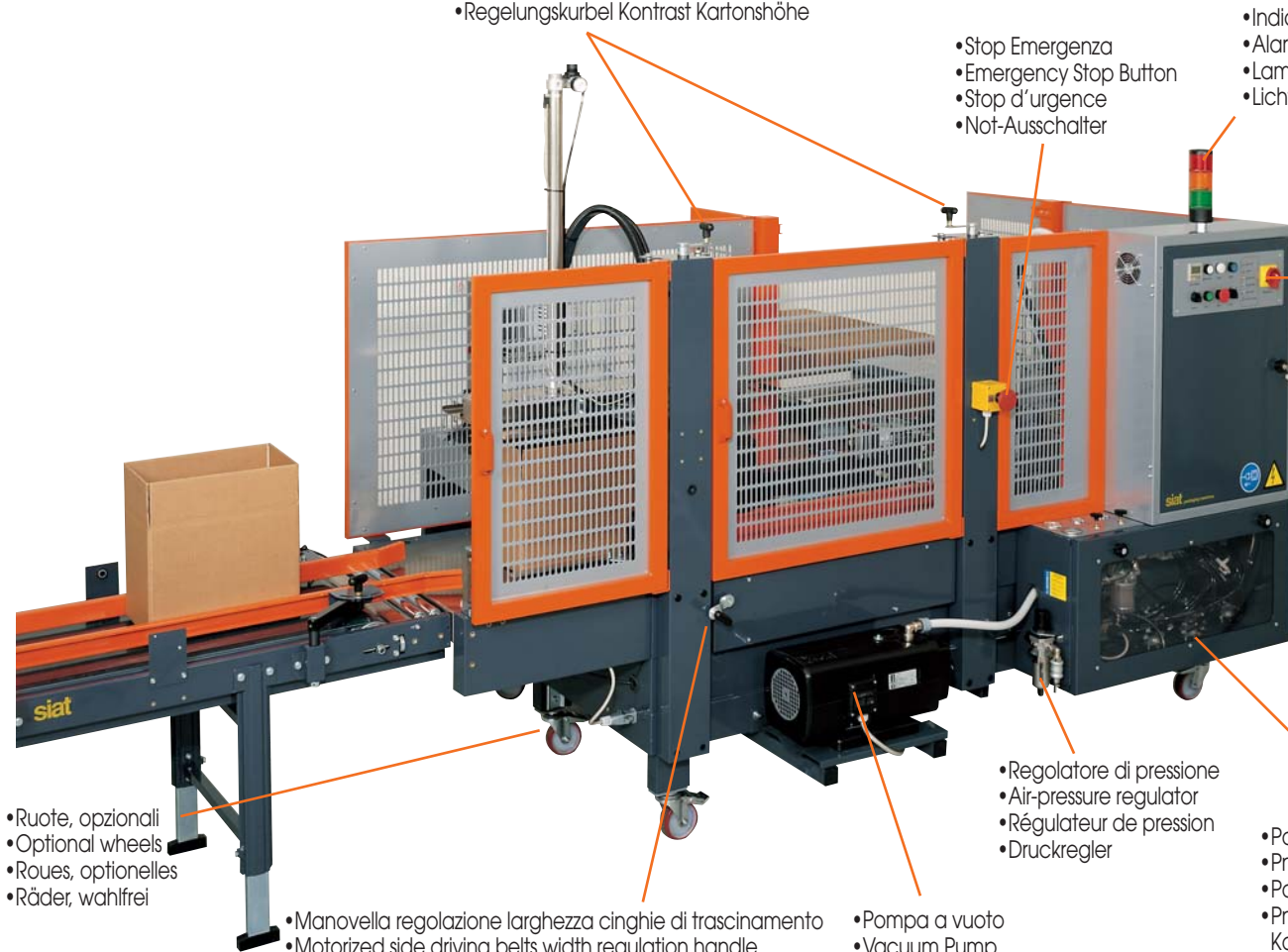

- Ruote, opzionali
- Optional wheels
- Roues, optionelles
- Räder, wahlfrei

- Manovella regolazione larghezza cinghie di trascinamento
- Motorized side driving belts width regulation handle
- Manivelle réglage largeur courroies d'entraînement
- Regelungskurbel Antriebsbänderbreite

- Pompa a vuoto
- Vacuum Pump
- Pompe à vide
- Vakuum Pumpe

- Regolatore di pressione
- Air-pressure regulator
- Régulateur de pression
- Druckregler

- Pannello pneumatico
- Pneumatic Control Panel
- Panneau pneumatique
- Pneumatische Kontrolltafel



- Applicatore adesivo Hot Melt
- Hot Melt glue generator
- Appliqueur adhésif Hot Melt
- Hot Melt Kleberanwender

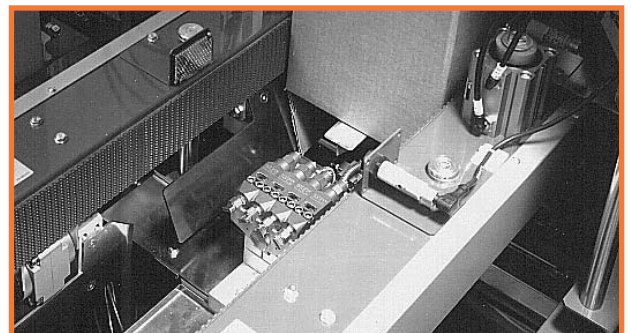

- Modulo applicazione colla Hot Melt
- Hot Melt glue applying head
- Tête d'application adhésif Hot Melt
- Modul zur Anwendung vom Hot Melt kleber

La formeuse automatique HM145 prélève, forme et colle avec Hot Melt les rabats inférieurs de boîtes carton, prêtes donc pour le remplissage. Elle peut préparer jusqu'à 700 boîtes/heure, selon le format. Les réglages de la machine au format de la boîte sont simples et rapides. Elle est conforme aux normes CE et ne demande pas du personnel spécialisé pour son fonctionnement.

Der automatische Fachschachtelaufrichter HM145 nimmt ab, bildet und klebt die unteren Klappen der Kartonschachteln mittels Hot-Melt Kleber, und schickt sie aus der nächsten Füllungsstufe bis eine max Leistung von 700 St./Stunde gemäss Kartonformates. Der Formatswechsel ist einfach und schnell. Er entspricht aller CE-Unfallverhütungsregeln, und ist entworfen worden, um eine einfache Bedienung auch ohne Fachleute zu bekommen.

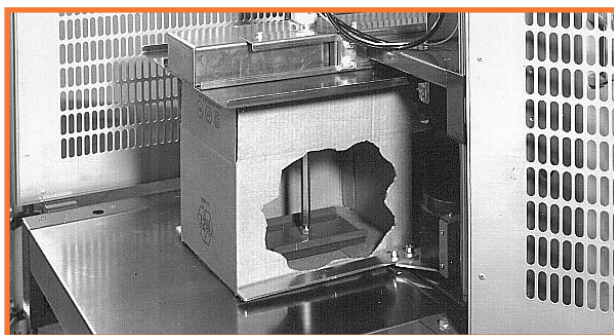
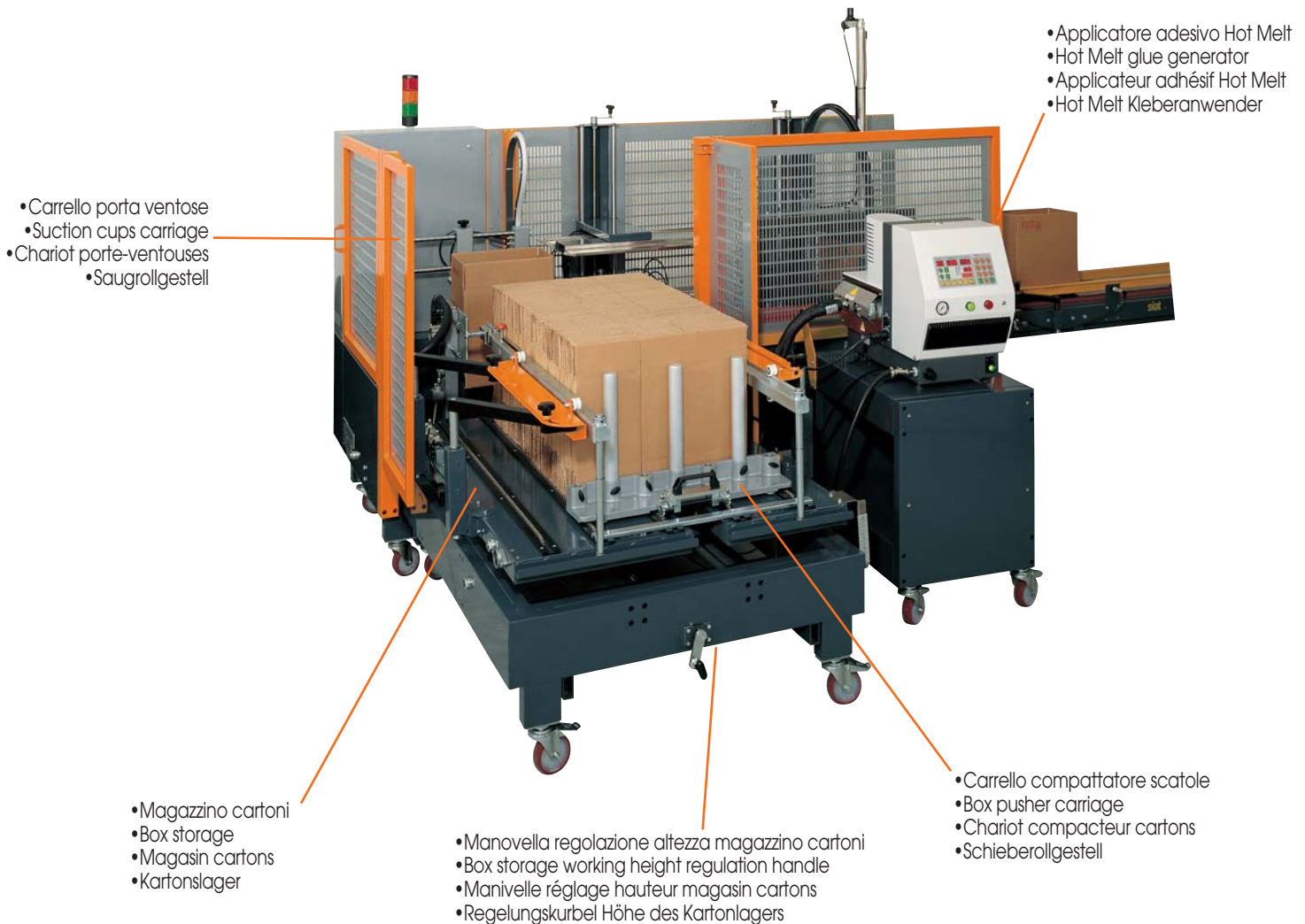

- Stabilizzatore falde interne scatola
- Bottom flaps stabilizer
- Stabilisateur rabats inférieurs
- Drucker der unteren Falten



- Pannello di controllo formatore
- Case erector control panel
- Panneau commandes formeuse
- Tafel zur Aufrichterkontrolle